

# IN-LINE+ Pool Heater

Installation & Operating Manual

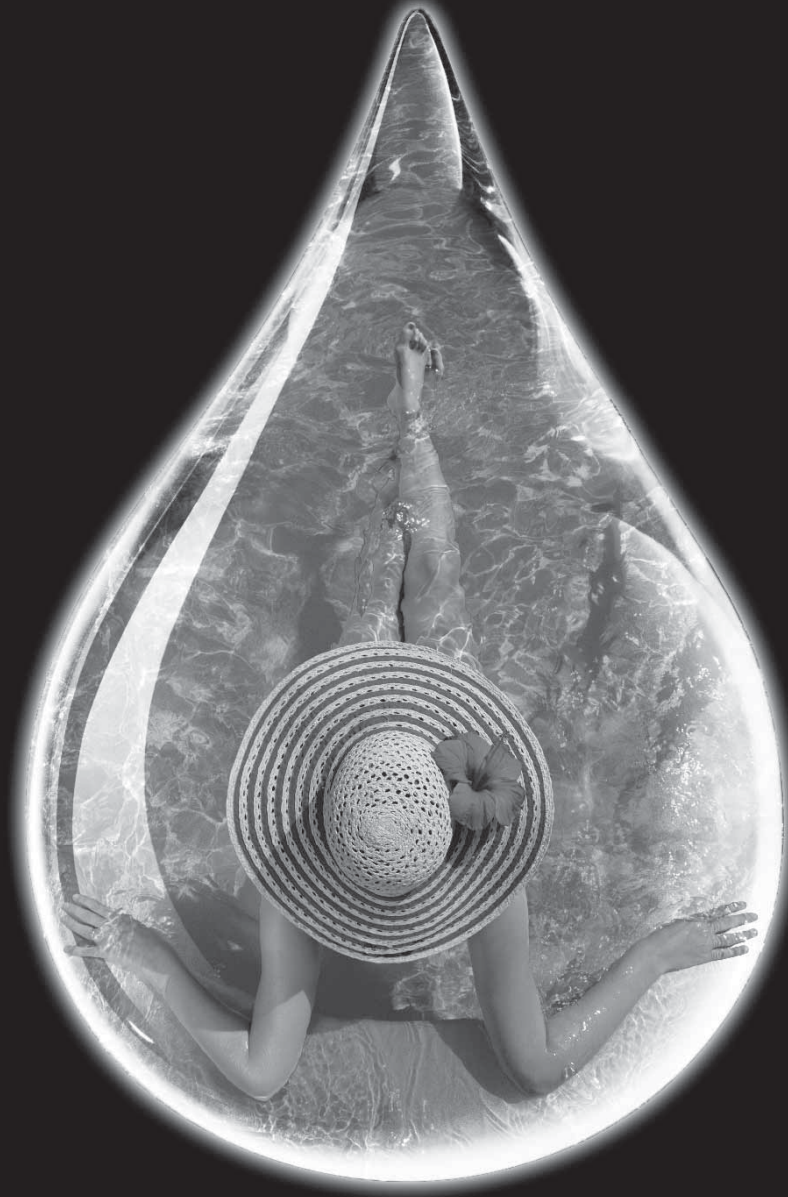

**ELECRO**

**ENGINEERING**

## Important Notes!

Thank you for purchasing the IN-LINE+ direct electric swimming pool heater manufactured in England to the highest standards.

To ensure your new heater will give years of trouble free service **please carefully read the following instructions. Incorrect installation will affect your warranty.**

Do not discard this manual, please retain for future reference.

## Product Overview

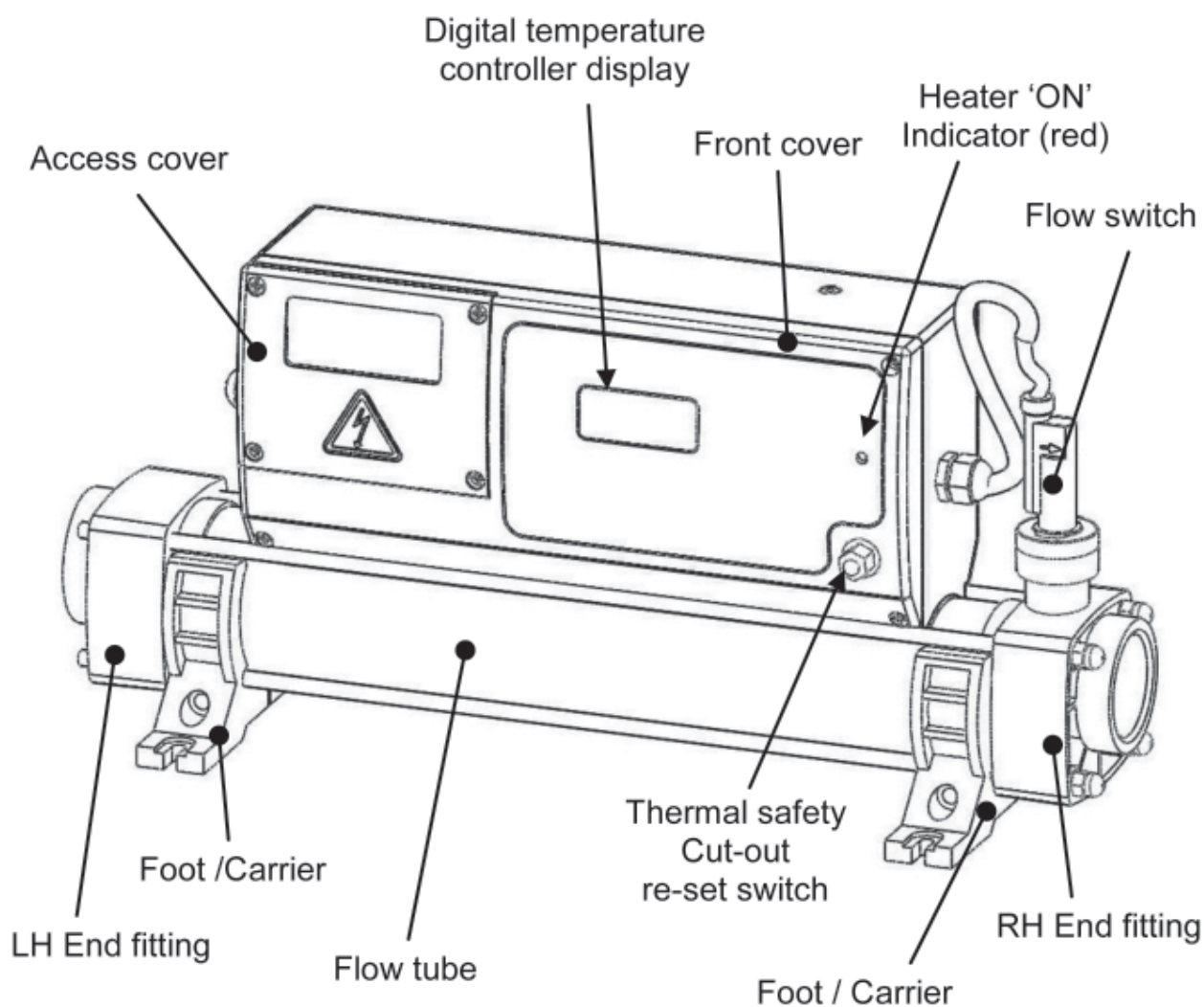

Fig 1.

## Positioning

Your heater should be horizontally or vertically sited allowing sufficient space for pipe connections and wiring, it should be screw fixed securely to a firm base or wall.

**NOTE: See figure 2 for details of the foot arrangement when securing to the wall or floor.**

### Floor mount 'Foot position'

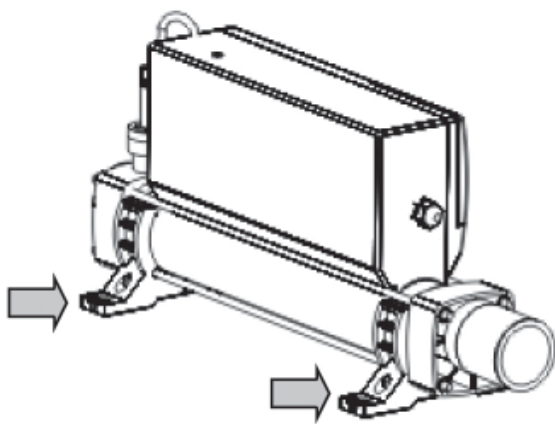

*Factory set floor mount 'Foot position'*  
*To reset for wall mount option, undo the bolts and re-assemble in the vertical position as shown.*

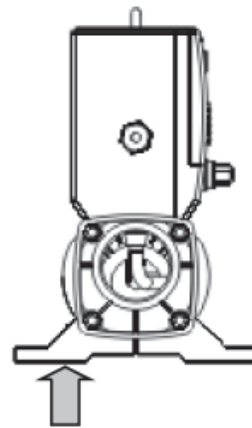
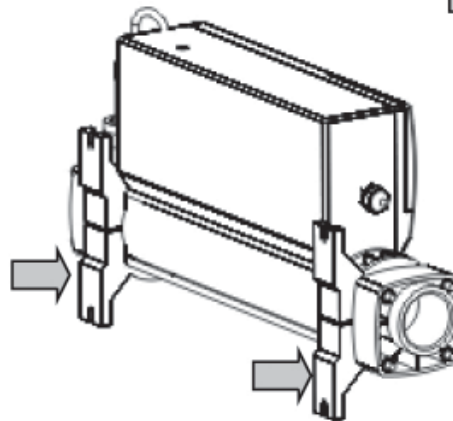
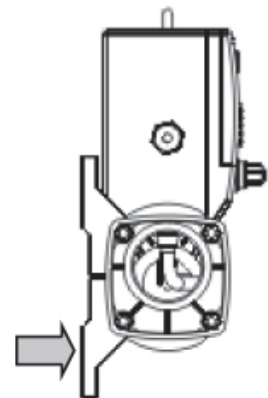

Fig 2.



### Wall mount 'Foot position'

The heater should be installed at a low point in the filtration system. It should be positioned downstream (after) of the filter and upstream (before) of any dosing or other water treatment plant. (see fig.3)

**NOTE : If the flow direction is reversed (explained later in this booklet) the heater must remain sited after the filter.**

Fig 3.

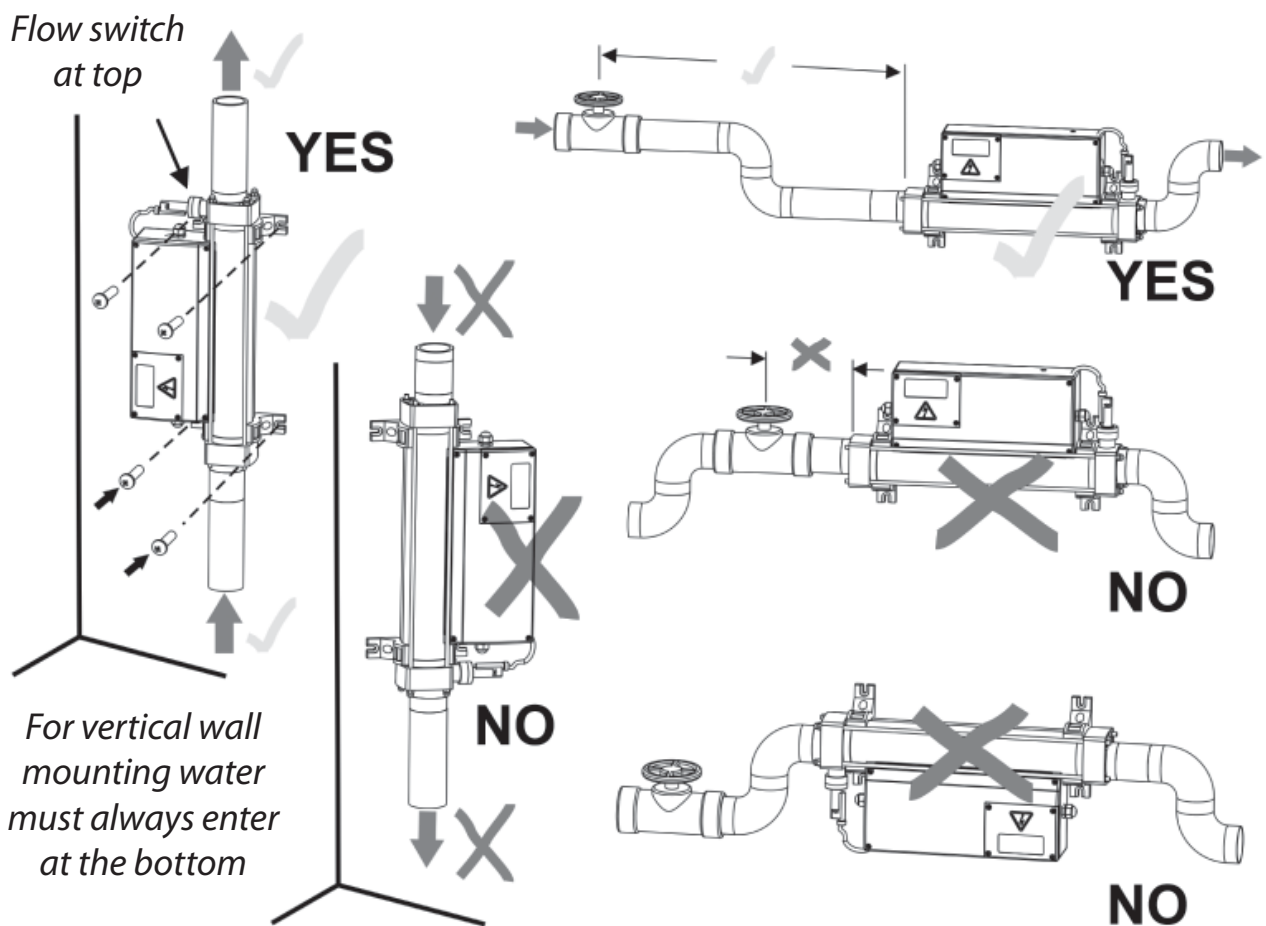
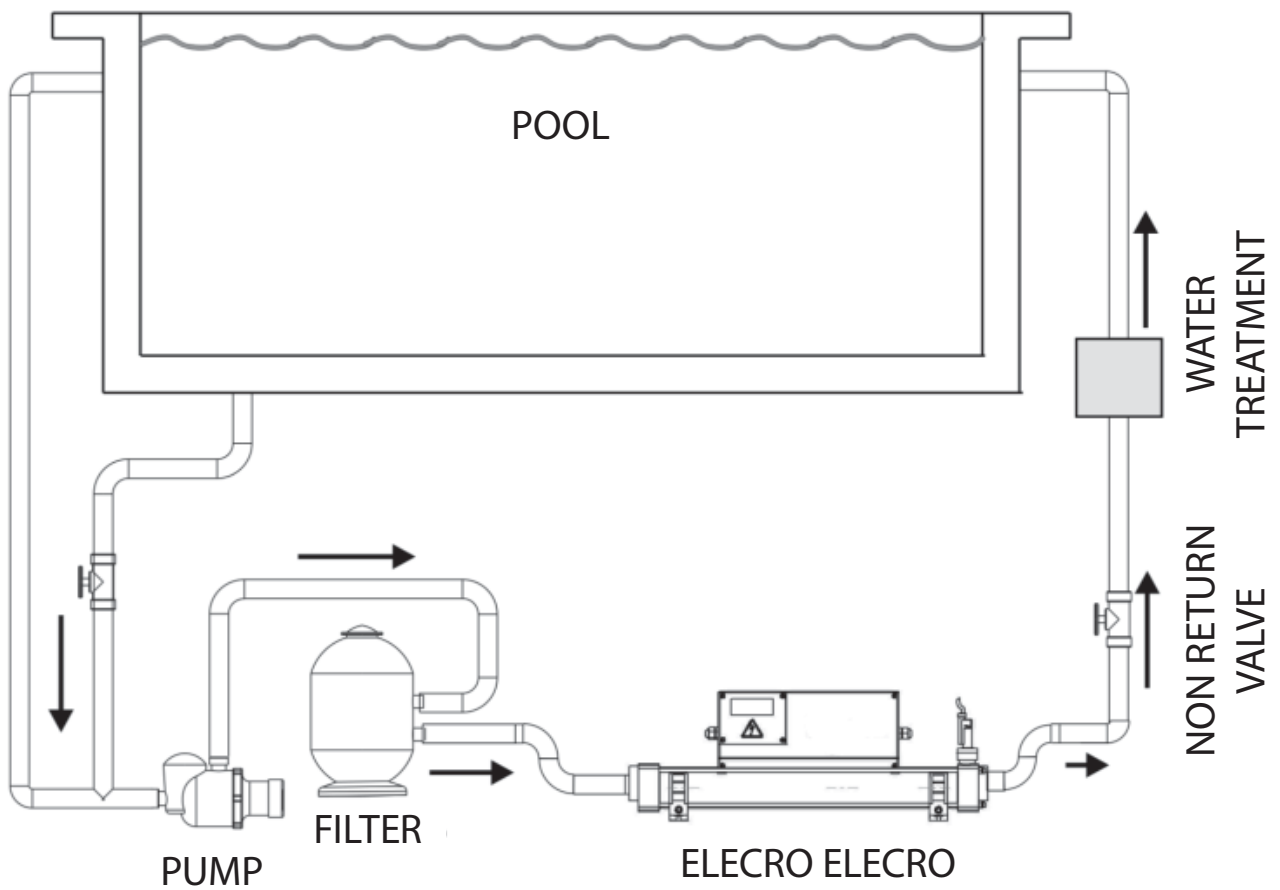

Fig 4.

## Pipe Work

It is essential that the pipe work connecting to and from the heater has a minimum bore (internal diameter) of 1¼" (32mm)

To assist correct air purging and to ensure the heater remains completely full of water during operation, the return pipe which carries the water back to the pool must incorporate a safety loop or 'kick-up' in the pipe as close as possible to the heater (see fig 4)

**NOTE: When coupling to a flexible pipe a safety loop can simply be created by routing the pipe up and over an obstacle. Remember to use pipe clips to securely fasten all hose connections.**

## Weather Protection

The heater must be installed within a dry weather proof enclosure.

**Caution!** *If the heater is not used during winter months it must be drained to prevent frost damage.*

## Electrical Connection

The heater must be installed in accordance with the country / regional requirements & regulations. In any event the work must be carried out by a qualified electrician, who will provide a certificate of conformity upon completion of the work. The power supply must be fitted with a RCD. If required your electrician may replace the supplied cable entry gland with a larger size to secure the cable powering the heater, this will not affect your warranty if carried out by a qualified electrician.

Cable section: This should be calculated at 5-amp / mm<sup>2</sup> for distances up to 20 metres (these sections are indicative and should be checked and adapted if necessary for cable lengths over 20 metres).

*Remove Access Cover  
to make the electrical  
connections  
(Qualified electricians only)*

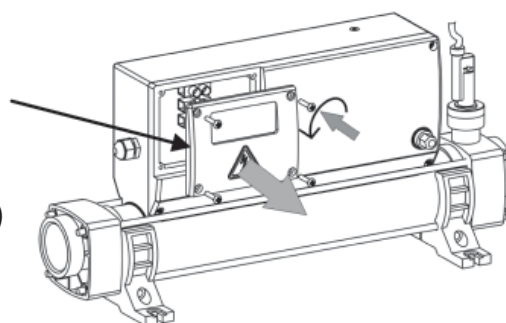

Fig 5.

## Power Requirements

Power Output	Voltage (V)	Amp
2 - kW	230	9
3 - kW	230	13
4.5 - kW	230	20
6 - kW	230	27
9 - kW	230	40
12 - kW	230	53
15 - kW	230	66
18 - kW	230	79

3 Phase Power Output	400 V Star / 230 V Delta	Amp
6 - kW	400 / 230	9 / 15
9 - kW	400 / 230	13 / 23
12 - kW	400 / 230	18 / 31
15 - kW	400 / 230	22 / 38
18 - kW	400 / 230	26 / 46
24 - kW	400	35

## Flow Requirements

Your heater is factory set to accept input water flow entering on the left and exiting on the right, this can be reversed by rotating the flow switch 180 degrees (ie: ½ turn, see fig 6)

**WARNING!** The flow switch paddle can be damaged when reversing the flow direction if it is lifted by more than 5mm from its housing and turned with force. If the flow switch has been rotated it is important to ensure that it is finally locked in the correct orientation perpendicular (at right angles) to the flow of water.

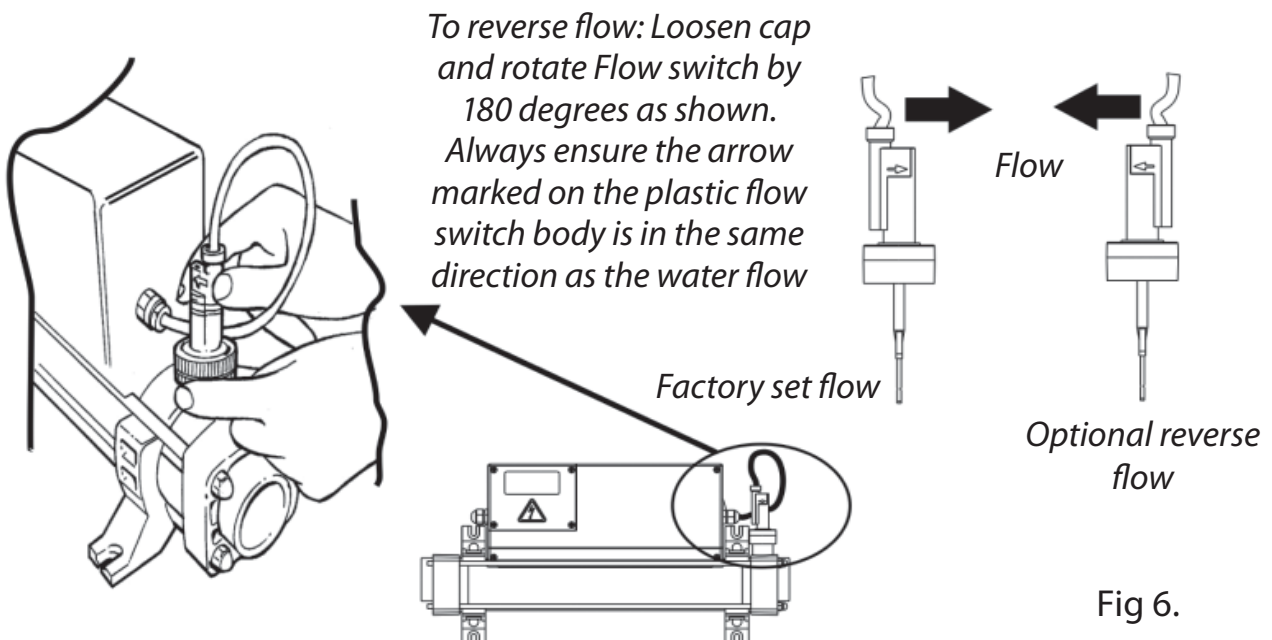

The flow rate of water into the heater must not exceed 17,000 litres per hour (3,740 UK gallons/hour) A higher flow rate will require the installation of a bypass to prevent damage to the heater elements. The heater will not operate unless the following minimum flow rates are achieved ie:

1,000 litres / hour (220 UK gallons/hour) for 2 ~ 6-kW heaters and  
4,000 litres / hour (880 UK gallons/hour) for 9 ~ 24-kW heaters.

## Water Quality

The water quality **MUST** be within the following limits:

PH 6.8 - 8.0

TA (Total alkalinity) 80—140ppm (parts per million)

Chloride Content MAX: 150 mg/litre

Free Chlorine: 2.0 mg/litre

Total Bromine: Max 4.5 mg/litre

TDS (Total Dissolved Solids) / Calcium hardness 200— 1,000ppm

Stainless Steel heaters are **NOT** suitable for use on saline (salt) water pools.

**ONLY** heaters with titanium heating elements are suitable for use on saline (salt) pools.

**Water chemistry is complicated if in doubt seek expert advise.**

## Operating Instructions





Upon completion of the installation, run the water-circulating pump to purge the system & heater of air (i.e. Remove any trapped air in the system & heater). **TIP:** You can encourage air out of the heater flow tube by gently elevating the exit port of the heater when the pump is running. On initial power up of the heater the amber light should illuminate.

The heater will only switch 'On' (red light indicator illuminated) and the amber light switching 'Off' when the following criteria are met ie:

- Water circulating pump is 'On' delivering in excess of the minimum flow rate of water (see flow requirement information)
- Temperature set point dial is set to a higher value than that of the water

# Digital Thermostat Controller

The digital controller fitted to the In-Line + heater has been pre-programmed with all the necessary parameters to ensure reliable service & operation. Below is a key explaining the controllers buttons & LED signals however these will all be explained in detail later in this booklet.

-  Press and hold for 2 seconds to power the control on / off.
-  Press to increase required pool temperature.
-  Press to decrease required pool temperature.
-  Press and release to activate / deactivate 'Priority of Heating'.

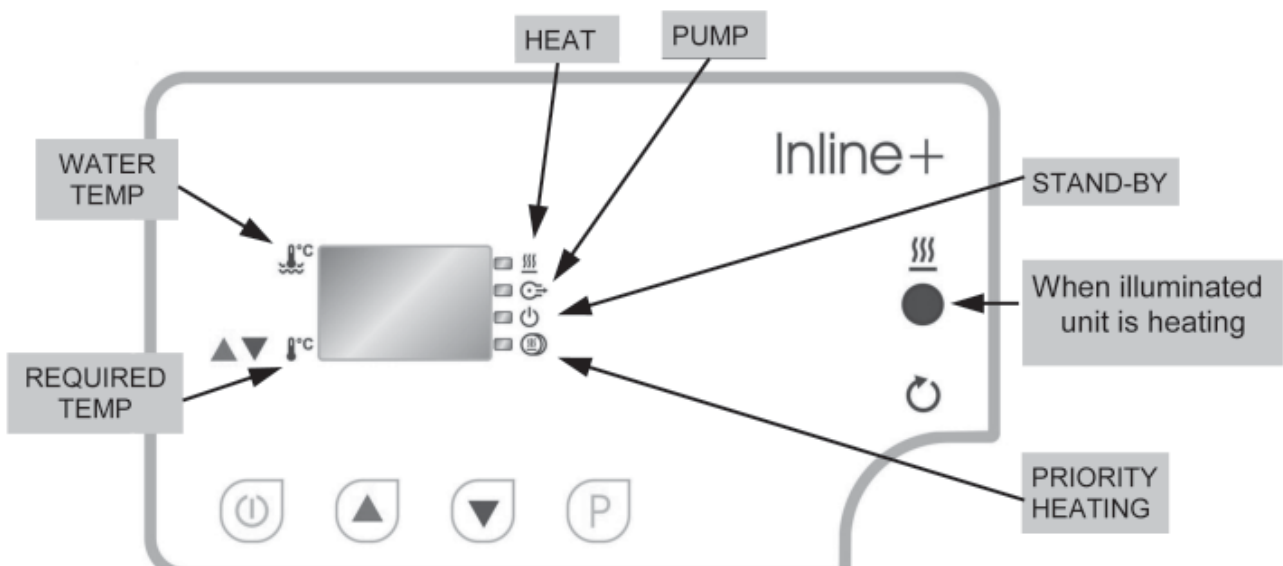

The actual pool temperature is displayed in the red upper display. The lower green display 'required temperature' can be selected by the user. This is the temperature you would like your pool water to be maintained at.

Priority of Heating is a function that ensures your pool water is constantly maintained at your required temperature. When Priority of heating is activated the Priority of Heating Icon on the bottom right of the display will illuminate. The control will now monitor the pool temperature, and start both the pool circulation pump and heating process when necessary - please see pump interlock section for details on how to connect the pump interlock cable



## Time Switching Delay

To prevent overheating of the switch components within the heater caused by frequent on and off switching (cycling), the In Line + digital controller has been pre-programmed with a time delay function. This prevents rapid fluctuations in temperature or velocity from switching the heater on and off more than once in a two minute period. The time delay mode is indicated by the flashing LED next to the word HEAT on the digital display.

## Differential

When the pool water has reached the required temperature the heater will switch off and will not switch back on until the water temperature has dropped 0.6°C. This value is known as the differential and is also in place to prevent overheating of the switch components caused by cycling.

## Pump Interlock Cable

The In-Line + heater is supplied complete with a pump interlock cable that connects into the left hand side of the heater enclosure, directly below the power in cable entry gland.

To connect simply remove the rubber protection cap from the female connector fitted to the heater enclosure, insert the male connector supplied on the 5m cable. When fully inserted rotate the locking nut onto the female connector so that the connector is locked in position.

The end of the cable has 2 wires that need to be connected in order to by-pass the time clock controlling the swimming pool pump.

**NOTE: Do NOT connect the pump interlock cable directly to the swimming pool pump as this will result in overloading the heaters digital controller. (See circuit diagram at back page).**

**Maximum permitted load is 5-Amp**

## HEATER WILL NOT SWITCH TO HEATER 'ON' MODE

In most cases this will be the result of one of the following not being met.

**Possible Cause 1:** The set point temperature has been achieved. To confirm that the digital controller is requesting the unit to heat check that the window next to the word HEAT is illuminated. If illuminated go to step 2, if not illuminated increase the required temperature to a value higher than the current water temperature. Confirm whether the heater now switches to HEATER ON mode.

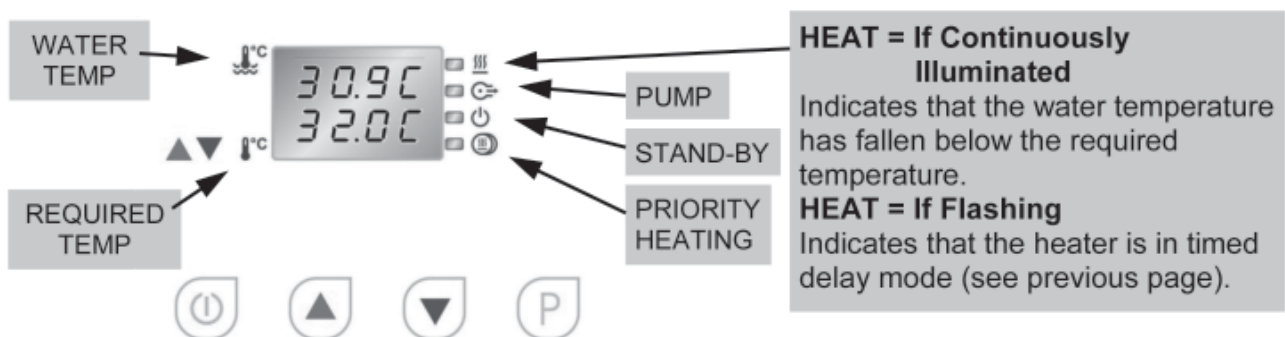

**Possible Cause 2:** The 'Thermal safety cut-out' has tripped.

**Remedy:** remove button cover and press red button to re-set (See diagram below). If a positive click is felt, the cause of the tripping must be investigated and could be caused by a debris build up or air pocket trapped inside the flow tube of the heater.

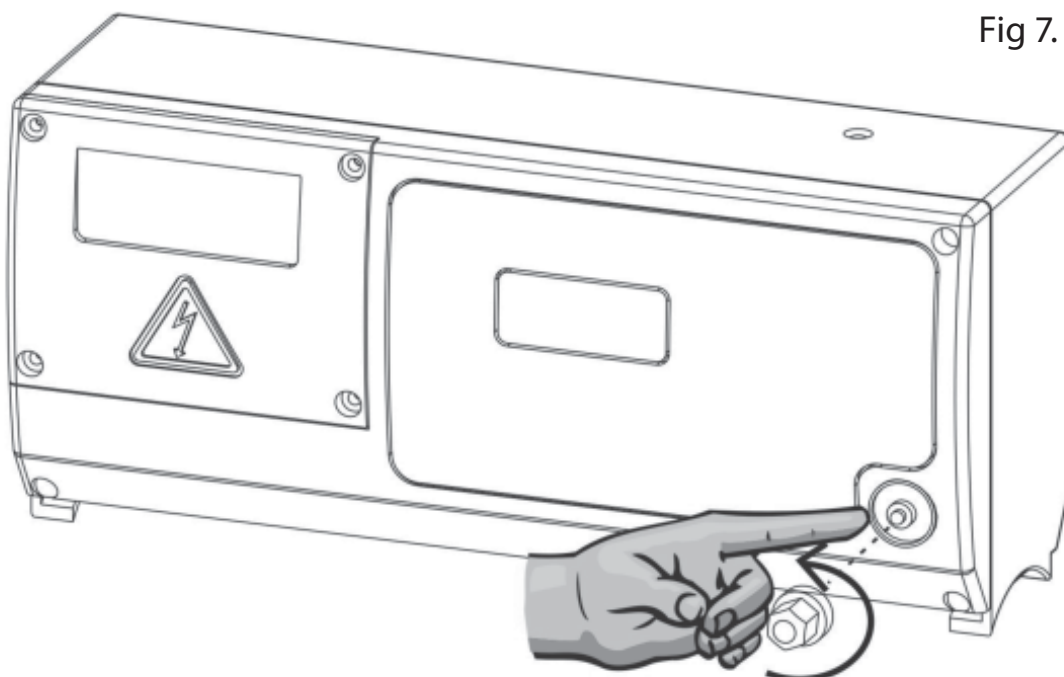

Fig 7.

**Possible Cause 3:** *Insufficient flow. The heater will display a 'noFL' alarm message in the upper (red) display window when the heater has detected that the flow rate has dropped below the minimum level or stopped completely.*

**If using a cartridge filter:** Confirm this by running the system with the cartridge removed from your pump & filter unit, this will supply the heater with the maximum flow rate your unit is capable of. If the heater then switches 'On' (ie: red light 'On') a blocked cartridge can be confirmed to be the cause. The cartridge should be cleaned or replaced.

**If using a sand filter:** Check the pressure indicator on your sand filter and back wash if necessary.

**Note:** In some cases the 'Thermal safety cut-out' tripping and a low flow rate can be linked ie: when a filter becomes choked air can be drawn into the filtration system and become trapped inside the heater so causing the thermostat to trip.

## Quick Function Test

Observe the property's main electricity meter when the heater is on (i.e. Red Heating indicator is illuminated) and then observe it again when the heater is in standby mode. The test should show that the meter is recording more electricity being used by the heater when the Heating indicator is illuminated. It is impossible for an electric heater to waste energy, if it is drawing power then that power will be turned into heat that will be transferred to the water.

## Accurate Function Test

If a more accurate test is required to confirm that your heater is delivering the specified heat output, two electricity meter readings will need to be taken from the property's main electricity meter, with an exact one hour interval (i.e. take one meter reading and then a second reading exactly one hour later). Then by subtracting the first reading from the second reading the number of units (kilo watts kW) consumed can be calculated. Note that your heater is also rated in kW hours. The pool pump and heater will need to be running continuously during the test (i.e. with the Heating indicator illuminated).

To avoid inaccurate results when performing this test, it is important to refrain from using other high current drawing appliances in the property (such as tumble dryer, showers, cooker etc).

A large domestic pool pump of 1-horsepower will draw less than 1-kW in a one hour period. The conclusion of the test should prove that for example a 6-kW heater and a ½ horsepower pump will draw between 6.3-kW to 6.5-kW in one hour. It is impossible for an electric heater to waste energy, if it is drawing power then that power will be turned into heat that will be transferred to the water.

## **NO LIGHT APPEARS ON THE HEATER WHEN IT IS SWITCHED 'ON'**

**Possible cause:** *Power failure external to the heater*

**Remedy:** Check any fuses, RCD or other switch components installed in the supply cable.

**Note: A fuse is fitted on the digital control circuit board on the inside of the enclosure (qualified electricians only).**

## **THE FLOW TUBE DOES NOT FEEL WARM**

Due to the high efficiency of your electric heater no warmth should be detectable from the flow tube of the heater.

The most likely causes of the flow tube feeling warm are:-

**Possible cause 1:** The heater has been positioned in direct sunlight.

**Possible cause 2:** An air pocket is trapped inside the heater particularly if the tank feels warmer at the highest point of the tank (as air rises).

**Q:** How long will it take to heat my pool?

**A:** **Assuming no heat losses**, and a heater sized in the ratio 1.5-kW per 1,000 UK gallons of water (4,545-litres): it will take 2 days of continuous running to raise the temperature of a pool from tap temperature to swimming temperature. Heat loss will slow the heating process, particularly during periods of cold weather, hence the higher the water temperature is to be maintained above average ambient air temperature, the slower the heating process will become.

The only influencing factors are the level of insulation and the location of the pool with regard to wind shelter.

**Useful advice:** To reduce running costs and speed up the heating process; Insulate the pool wherever possible. A floating solar cover is an essential minimum to retain heat.

## RoHS Compliance Statement

Elecro Engineering Limited certify that our Electric Swimming Pool Heater Range complies in accordance with RoHS Directive 2002/95/EC on the restriction of hazardous substances.

## Waste of Electrical / Electronic Equipment

This product complies with EU directive 2002/96/EC

**Do Not dispose of this product as unsorted municipal waste.**

This symbol on the product or on it's packaging indicates that this product should not be treated as household waste. Instead it should be handed over to the applicable collection point for the recycling of electrical and electronic equipment.



By ensuring this product is disposed of correctly you will help prevent potential negative consequences for the environment and human health, which could otherwise be caused by inappropriate waste handling of this product. The recycling of materials will help to conserve natural resources.

For more information please contact your local Civic office, your household waste disposal service or the retailer where you purchased the product.

***Your heater is guaranteed from the date of purchase against faulty workmanship and materials ie: 2 years guarantee for incoloy heating element products and 3 years guarantee for titanium heating element products.***

The manufacturer will replace or repair, at it's discretion, any faulty units or components returned to the company for inspection.  
Proof of purchase may be required.

The manufacturer will not be liable in cases of incorrect installation of the heater, inappropriate use or neglect of the heater.

### **CE Declaration Of Conformity**

The manufacturer declares that the herewith products or ranges

#### **ELECTRIC SWIMMING POOL HEATER RANGE**

Are in conformity with the provisions:  
of the ELECTROMAGNETIC COMPATIBILITY directive 89/336/EEC, as amended 93/068/EEC. Controlled by AEMC Measures laboratory—  
technical report no P96045T

The harmonised standards have been applied: EN 55014—EN 55104

**EN 55011**

**EN 55022**

**CEI 801-4**

**CEI 801-2**

**CEI 801-3**

of the LOW VOLTAGE directive 73/23/EEC.

The harmonised standards have been applied

**EN 60335-2-35**

## In-Line+ Single Phase 230V

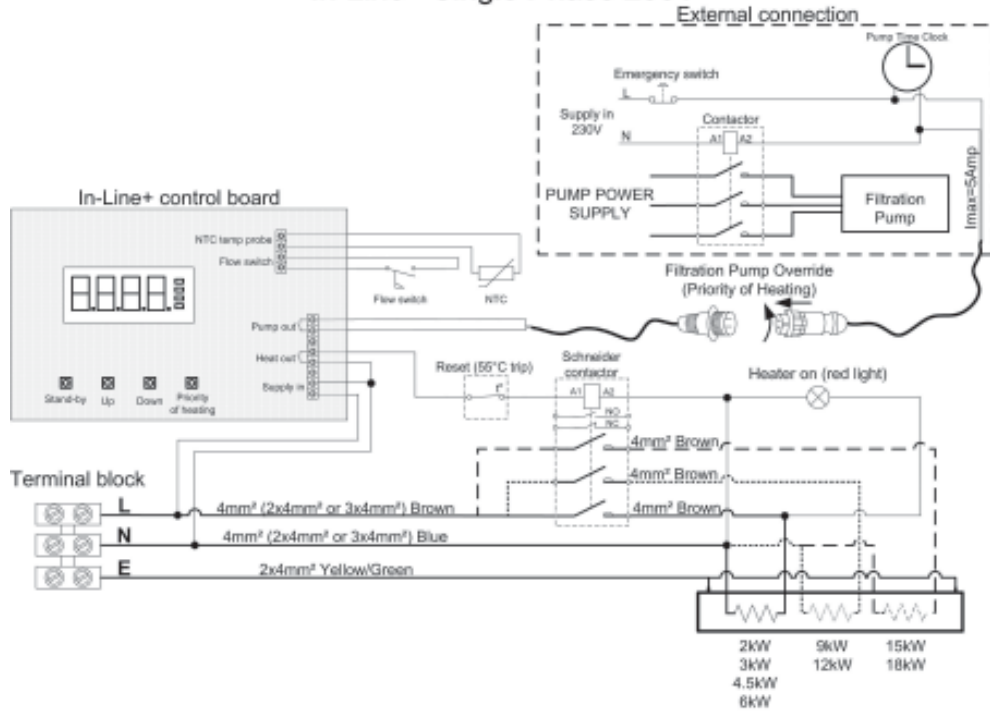

## In-Line+ 3 Phase 400V (6,9,12,15,18kW)

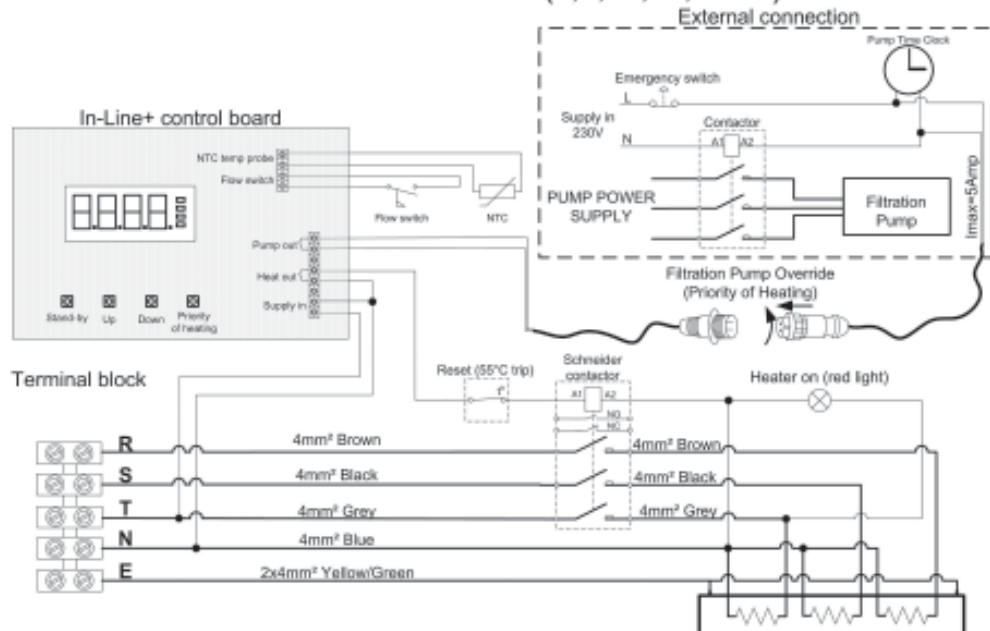

## In-Line+ 3 Phase 400V (24kW delta)

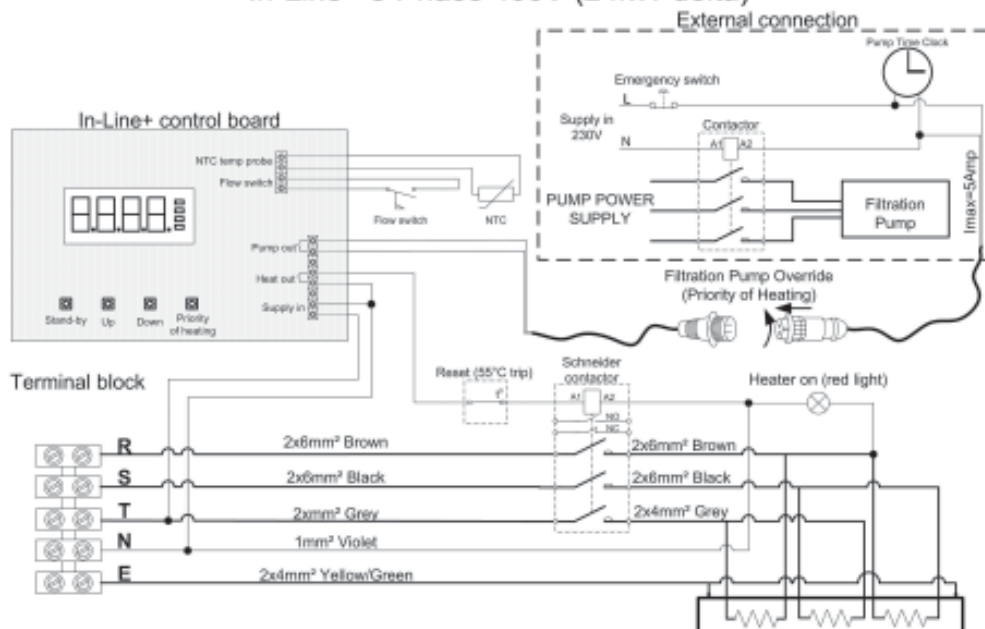



11 Gunnels Wood Park | Stevenage | Hertfordshire | SG1 2BH | United Kingdom

t: +44 (0) 1438 749 474 | f: +44 (0) 1438 361 329 | e: [info@elecra.co.uk](mailto:info@elecra.co.uk)

[www.elecra.co.uk](http://www.elecra.co.uk)